

Wall-Hung Urinal IntegraSense

PRODUCT FEATURES

- Integrated sensor activation urinal
- Low lip design suitable for children
- Mechanical override button
- Low water consumption
- Compact design with internal trap
- Compliance to BCA barrier-free design

FLUSHING TYPE

- Integrated sensor with manual overriding button

PRODUCT SPECIFICATIONS

- Dimension : 430 (L) x 430 (W) x 1040 (H) mm
- Material : Vitreous China
- Operating Pressure : 100 kPa - 800 kPa

DISCHARGE VOLUME

- Discharge Volume : 1.5L/flush



RESOURCEFUL FEATURES:



Water Spreader Device



Anti-Bacterial Technology



RC1000 Remote Control



Build in Manual Overriding Button

TECHNICAL DRAWING

INSTALLATION DETAILS

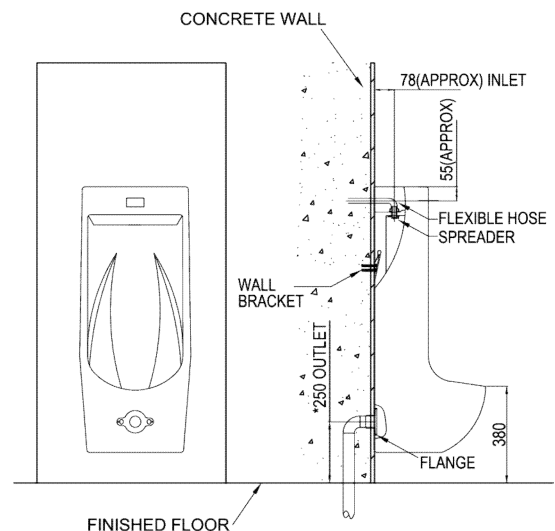
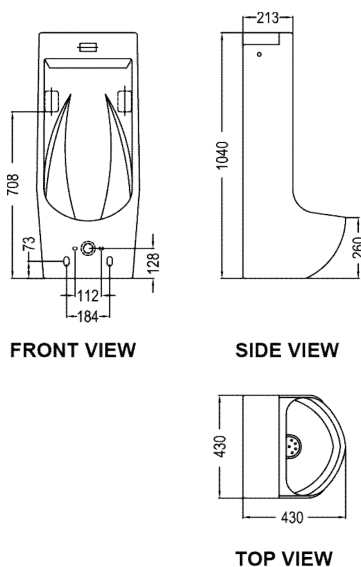

Copyright © Rigel Technology (S) Pte Ltd All rights reserved. Terms of Use.